

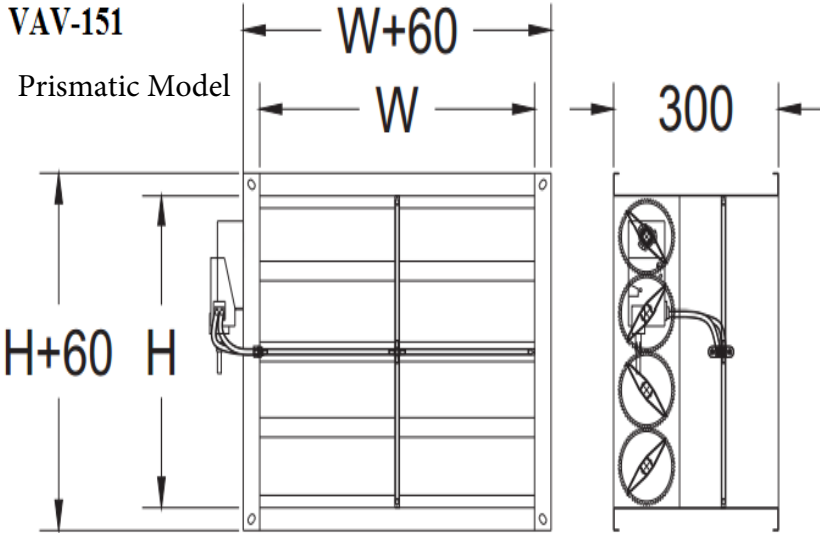

MODEL VAV

VARIABLE AIR VOLUME CONTROL DAMPERS

Project:
Tag:
Engineer:
Contractor:
Date:



Size (WxH) (mm)	u:2m/s V _{min.} (m ³ /h)	u:10m/s V _{nom.} (m ³ /h)	A _{eff.} (m ²)
200x205	259	1296	0,036
300x205	396	1980	0,055
400x205	525	2628	0,073
500x205	655	3276	0,091
300x305	568	2844	0,079
400x305	756	3780	0,105
500x305	950	4752	0,132
600x305	1137	5688	0,158
700x305	1332	6660	0,185
800x305	1519	7596	0,211
400x405	993	4968	0,138
500x405	1245	6228	0,173
600x405	1490	7452	0,207
700x405	1742	8712	0,242
800x405	1987	9936	0,276
500x505	1533	7668	0,213
600x505	1843	9216	0,256
700x505	2152	10764	0,299
800x505	2455	12276	0,341

- V_{min.}(m³/h)** : Air flow rate when air velocity is 2 m/s
- V_{nom.}(m³/h)** : Air flow rate when air velocity is 10 m/s
- V_{max.}(m³/h)** : Air flow rate that customer wants between V_{min.} and V_{nom.} limit values
- u (m/s)** : Air velocity at VAV unit inlet
- A_{eff.} (m²)** : Effective area

VAV-251 Circular Model

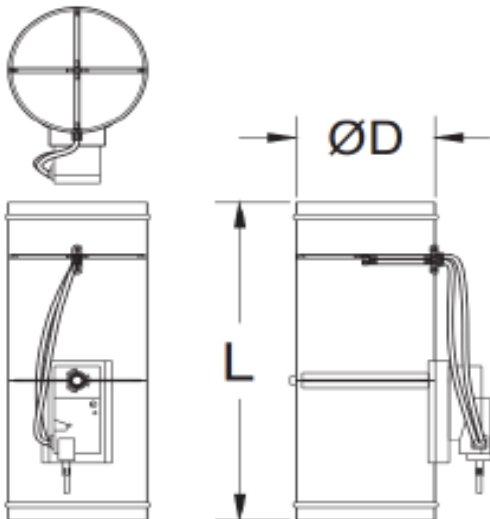

Size	u:2m/s V _{min.} (m ³ /h)	u:12m/s V _{nom.} (m ³ /h)	ØD (mm)	L (mm)
Ø125	90	520	123	450
Ø160	150	870	158	450
Ø200	230	1360	198	500
Ø250	360	2120	248	500
Ø315	560	3370	313	500
Ø355	710	4280	353	550
Ø400	910	5450	398	550

- V_{min.}(m³/h)** : Air flow rate when air velocity is 2 m/s
- V_{nom.}(m³/h)** : Air flow rate when air velocity is 12 m/s
- V_{max.}(m³/h)** : Air flow rate that customer wants between V_{min.} and V_{nom.} limit values
- u (m/s)** : Air velocity at VAV unit inlet
- ØD (mm)** : VAV unit internal diameter
- L (mm)** : VAV unit length

As part of our continuous improvement program, we reserve the right to make further improvements without notice.

Date submitted: